

Genie Z-45/25 & Z-45/25J DC & Bi-Energy Specifications

Articulated Booms

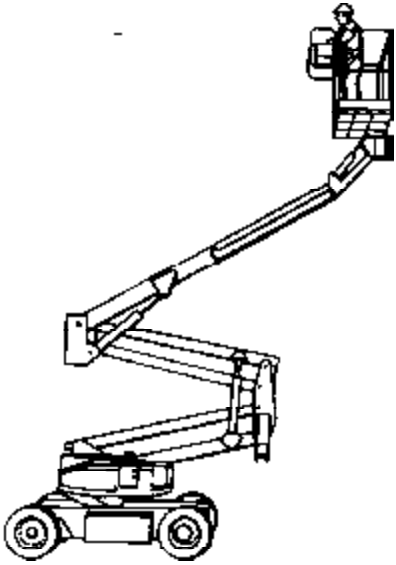

SPECIFICATIONS

	Z-45/25		Z-45/25J	
	<i>US</i>	<i>Metric</i>	<i>US</i>	<i>Metric</i>
Working height	51 ft 5 in	15.8 m	51 ft 3 in	15.8 m
Platform height	45 ft 5 in	13.8 m	45 ft 3 in	13.8 m
Height - stowed	6 ft 7 in	2 m	6 ft 7 in	2 m
Length - stowed	18 ft	5.5 m	22 ft 3 in	6.8 m
Width	5 ft 9 in	1.75 m	5 ft 9 in	1.75 m
Wheelbase	6 ft 8 in	2.03 m	6 ft 8 in	2.03 m
Ground clearance - center	8 1/2 in	22 cm	8 1/2 in	22 cm
Ground clearance - min	7 in	18 cm	7 in	18 cm
Platform length	30 in	76 cm	30 in	76 cm
Platform width	72 in	1.83 m	72 in	1.83 m
Horizontal reach max	24 ft 6 in	7.5 m	25 ft 3 in	7.7 m
Up and over clearance	22 ft 6 in	6.9 m	22 ft 6 in	6.9 m
Lift capacity	500 lb	227 kg	500 lb	227 kg
Turning radius - inside	5 ft	1.52 m	5 ft	1.52 m
Turntable rotation	359°		359°	
Tailswing	zero		zero	
Platform rotation	180°		160°	
Power source	48V DC (8 6V 315 AH batteries) or 48V DC with Kubota Diesel 12 hp (9 kw)			
Drive speed - stowed	3 mph	4.8 km/h	3 mph	4.8 km/h
Drive speed - raised	0.6 mph	1 km/h	0.6 mph	1 km/h
Lift speed to full height	90 sec		90 sec	
Controls	24V DC proportional		24V DC proportional	
Auxiliary power unit	24V DC		24V DC	
Tires	9 - 14.5		9 - 14.5	
Gradeability - stowed	30%		30%	
Hydraulic tank capacity	8 gal	30 litre	8 gal	30 litre
Fuel tank capacity	9 gal	34 litre	9 gal	34 litre
Weight - DC	15,900 lb	7,214 kg	16,100 lb	7,305 kg
Weight - Bi-Energy	16,100 lb	7,305 kg	16,300 lb	7,396 kg

STANDARD FEATURES

- Multiple disc brakes provide smooth deceleration
- Maintenance-free pivot-point bearings
- 500 lb (227 kg) lift capacity
- Fully proportional controls
- 180° hydraulic platform rotation on Z-45/25 models
- 160° hydraulic platform rotation on Z-45/25J models
- AC wiring to platform
- Drive enable system
- Swing-out battery packs
- Auxiliary power unit
- Hour meter
- Tilt alarm
- Horn

Genie Industries

USA 18340 NE 76th Street
P.O. Box 97030
Redmond, Washington 98073-9730
Telephone (425) 881-1800
Toll Free USA/Canada 800-536-1800
Fax (425) 883-3475
<http://www.genielift.com>

UK The Maltings, Wharf Road
Grantham
Lincolnshire NG31 6BH
Telephone +44 (0)1476-584333
Fax +44 (0)1476-584334
<http://www.genielift.com>

Continuous improvement of our products is a Genie policy. Product specifications are subject to change without notice or obligation. The drawings in this brochure are for illustrative purposes only. Refer to the appropriate Genie Z-45/25 and Z-45/25J Operator's Manual for instructions on the proper use of this equipment. Failure to follow the appropriate Operator's Manual when using a Genie Z-45/25 or Z-45/25J, or to otherwise act irresponsibly, may result in serious injury or death. Copyright © 1998 by Genie Industries. "Genie" is a Registered Trademark of Genie Industries in the USA and many other countries. "Z" is a Registered Trademark and